

FUTEK MODEL LCF555

LOW PROFILE UNIVERSAL PANCAKE LOAD CELL (Previously L2901)

Drawing Number: FI1099-C

INCH [mm] R.O.= Rated Output

WIRING CODE (CC1)			
+Excitation	-Excitation	+Signal	-Signal
RED PIN 'A'	BLACK PIN 'B'	GREEN PIN 'C'	WHITE PIN 'D'
+Sense	-Sense		
ORANGE PIN 'E'	BLUE PIN 'F'		

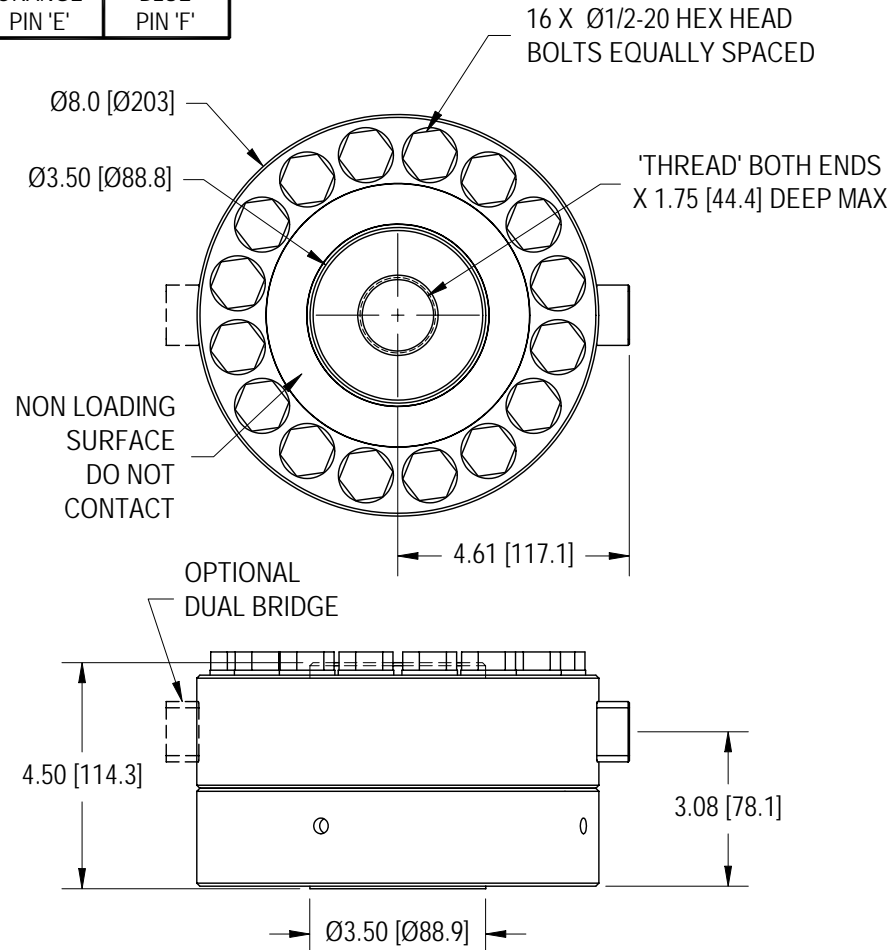
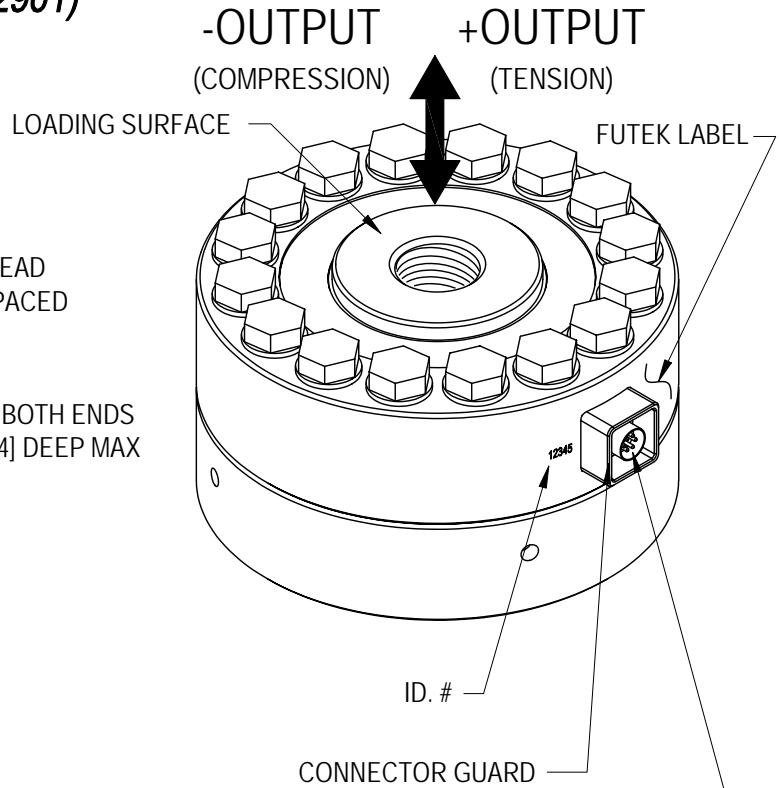

BENDIX RECEPTACLE
PT02A-10-6P
MATING CONNECTOR
PT06A-10-6S-SR
(NOT INCLUDED)

SPECIFICATIONS:

CAPACITY	100 Klb [445 kN]
RATED OUTPUT	4 mV/V nom.
SAFE OVERLOAD	150% of R.O.
ZERO BALANCE	±1% of R.O.
EXCITATION (VDC OR VAC)	20 MAX
BRIDGE RESISTANCE	350 Ω nom
NONLINEARITY	±0.1% of R.O.
HYSTERESIS	±0.2% of R.O.
NONREPEATABILITY	±0.02% of R.O.
CREEP	±0.02% of LOAD
TEMP. SHIFT ZERO	±0.001% of R.O./°F [0.0018% of R.O./°C]
TEMP. SHIFT SPAN	±0.002% of LOAD/°F [0.0036% of LOAD/°C]
COMPENSATED TEMP.	60 to 160°F [15 to 72°C]
OPERATING TEMP.	-60 to 200°F [-50 to 93°C]
DEFLECTION	0.005 [0.13] nom.
MATERIAL	17-4PH S.S.
WEIGHT	50 lb [22.7 kg]
CONNECTOR: 6 Pin BENDIX Receptacle (PT02A-10-6P)	
ACCESSORIES AND RELATED INSTRUMENTS AVAILABLE	
CALIBRATION (STD)	5 pt. COMPRESSION; 30 KΩ SHUNT CAL. VALUE
CALIBRATION (AVAILABLE)	5 pt. TENSION
CALIBRATION TEST EXCITATION	10 VDC

STOCK NO:	THREAD	DUAL BRIDGE
FSH02837	1 3/4-12-2B	
FSH02841		X
FSH02756	M42x2-4H	
FSH02840		X

REFER TO LCF551 FOR VERSION WITHOUT BASE PLATE

OTHER AVAILABLE RECEPTACLES & MATING CONNECTORS

BENDIX RECEPTACLE (PC04E-10-6P)
BENDIX MATING CONNECTOR (PC06E-10-6S-SR)